

POWERFAB

1500X 1700X

1.5-1.7
TON

DIGGING FORCE

3.4M DIGGING REACH

2.3M DEPTH OF DIG

360° continuous rotation



OFF SET DIG
(Optional)

180°
BOOM SLEW
(90°/50° left or right)

1500X 1.5 TON DIGGING
1700X 1.7 TON FORCE

CRAWLER EXCAVATOR

- FULL 360° PLATFORM ROTATION
- CONTROL LEVERS SIMILAR TO LARGER MACHINES
- CAN BE FITTED WITH VARIOUS DIESEL AND PETROL ENGINES
- EASY ACCESS TO MACHINE FROM BOTH SIDES
- WORKS IN CONFINED SPACES WITH ITS SHORT 1.15M TAIL SWING
- REINFORCED RUBBER TRACKS
- ENCLOSED CAB AVAILABLE

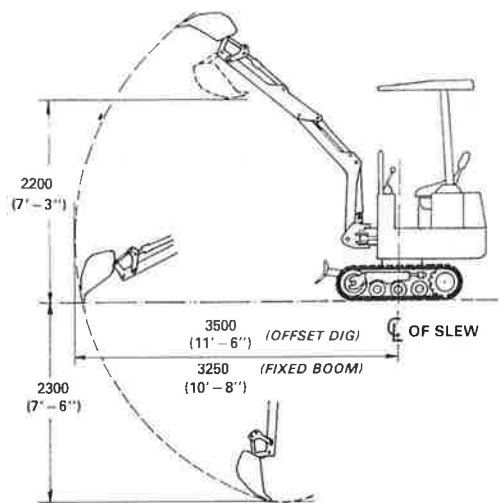

The standard machine has a fixed Boom. The optional Offset Dig version provides an independent Boom Swing for digging close and parallel to a wall or bank as shown below.

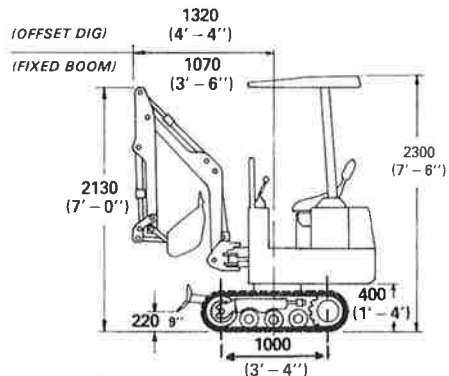

For offset digging alternative, two hole cylinder connection enables you to select a boom swing of 90° to the left or right with a 50° swing in the opposite direction — a total swing capability of 180°

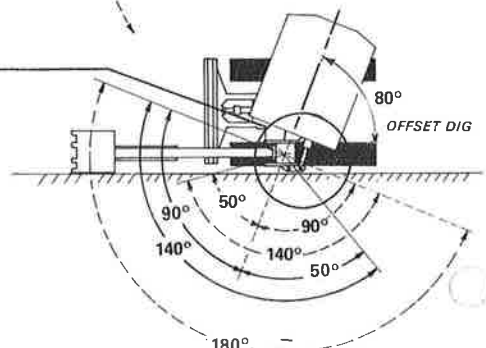
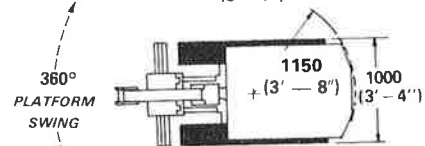

OPERATING DIAGRAM

SPECIFICATIONS

ITEM	DESCRIPTION	TECHNICAL DATA
ENGINE	1500 { Briggs & Stratton Vanguard	15 H.P. Air Cooled 2 Cylinder Petrol
	Mitsubishi L2E 11.2 KW at 3500 R.P.M.	2 Cylinder Water Cooled Electric Start Diesel
	1700 { Mitsubishi L3E 14.9 KW at 3000 R.P.M.	3 Cylinder Water Cooled Electric Start Diesel
	Lister Petters LP WS2 14.7 KW at 3,000 R.P.M.	2 Cylinder Water Cooled Electric Start Diesel
PERFORMANCE	Gradeability Slewing Speed Offset Boom Swing Angle Platform Swing Angle Travelling Speed Ground Contact Pressure	58% (30°) 9 R.P.M. 180° (Total) 360° 1.76 km/hr / 1.1 m.p.h. 0.25 to 0.30 Kg per cm ²
BUCKET	Standard Bucket	Capacity 0.045 M ³ Width 400mm
	Deep Bucket	Capacity 0.052 M ³ Width 400 mm
HYDRAULIC SYSTEM	Single Pump Flow Main Life Relief Pressure	1500 - 21 LPM 1700 - 33 LMP 186 Bar
	Tandem Pump Flow Main Line Relief Pressure	26 L.P.M. 186 Bar
UNDERCARRIAGE	Track Width No. of Rollers	Reinforced Rubber 200mm 3 per Track
DOZER BLADE	Width x Height Lift and Drop	1000 x 230 Lift 220 Drop 130
SHIPPING DIMENSIONS	Standard Length x Width x Height	2040 x 1020 x 2200
	Offset Dig Length x Width x Height	2300 x 1020 x 2200
MASS	Operating Weight	1.2 Ton to 1.35 Ton

MAJOR DIMENSIONS

BUCKETS

A RANGE OF EXCAVATOR BUCKETS ARE AVAILABLE IN WIDTHS RANGING FROM 200mm TO 600mm) SPECIAL PURPOSE ATTACHMENTS INCLUDING GRABS, FACE SHOVELS, GRAVE DIG BUCKETS AND MATERIAL HANDLING BUCKETS ARE ALSO AVAILABLE

ANCILLARY EQUIPMENT

THE OPTIONAL H.P.T.O. CONNECTIONS ENABLE YOU TO POWER A RANGE OF HYDRAULICALLY OPERATED IMPLEMENTS. THESE INCLUDE BREAKERS, CIRCULAR AND CHAIN SAWS, DRILLS, POLE HOLE BORERS, BRUSHES, WATER PUMPS, PRUNERS ETC

Due to our policy of continual improvement, we reserve the right to ammend design or specifications without prior notice.

For further information contact our Sales Dept. at the address given below.

Your Powerfab Distributor.

POWERFAB
SALES & SPARES LIMITED
FAIR VIEW, ASHVALE,
TREDEGAR, GWENT NP2 3HA
UNITED KINGDOM.
TELEPHONE: 049525 - 6627.
TELEX: 498973 POWFAB G.
FAX: 0495 - 718162

LEXPRINT OF RISCA

Patents Pending