

# JOLLY

Operations and maintenance manual for "JOLLY".

---

---



PLANT & HYDRAULICS (U.K.) LTD  
231, Bradford Road, Bailie, West Yorkshire WF17 6UL  
Tel: STD (0924) 455090 (0924) 454821  
Telex: 556188 (PHYDRA) G

*Specialists in Hydraulic Breakers*

## EUROMAGH

25018 MONTICHIARI (Brescia) Italy

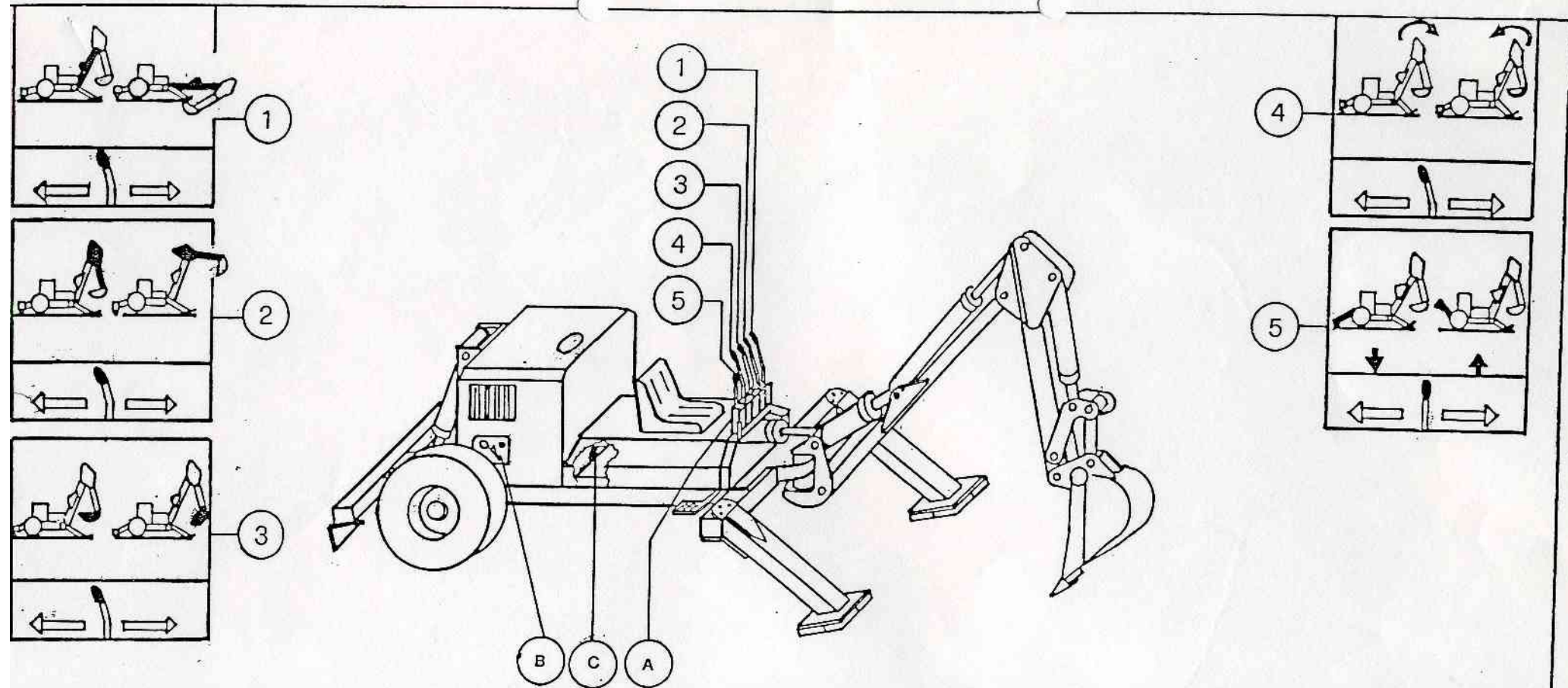

## OPERATION AND POSITIONING OF CONTROLS FOR EXCAVATOR MODEL "JOLLY".

1. - Control lever for movement of the first arm.
2. - Control lever for movement to the second arm.
3. - Control lever for the movement of the bucket.
4. - Control lever for the rotation of the arms.
5. - Control lever for the rear anchor.

## FUNCTIONS AND LEVER CONTROLS FOR THE PRINCIPAL WORKING MECHANISM OF THE MACHINE.

- A. - Control lever for the accelerator of the engine.
- B. - Control lever to stop engine.
- C. - Indicator for hydraulic oil level in the tank.

## IMPORTANT INSTRUCTIONS WHEN OPERATING THE EXCAVATOR.

Before starting the machine check the hydraulic oil level, the engine oil level and the state of greasing in the various mechanical parts.

Before starting the operations of digging run the engine for a brief period of time at least to warm the oil to the right viscosity.

Never continue to operate the levers once the movements have reached their complete run, if abused this could overheat the hydraulic oil.

Do not operate the levers to lower the arms when the engine is switched off. When the arms are down (on the floor), after having switched off the engine, remove the residual pressure in the hydraulic circuit by moving the control levers in both directions.



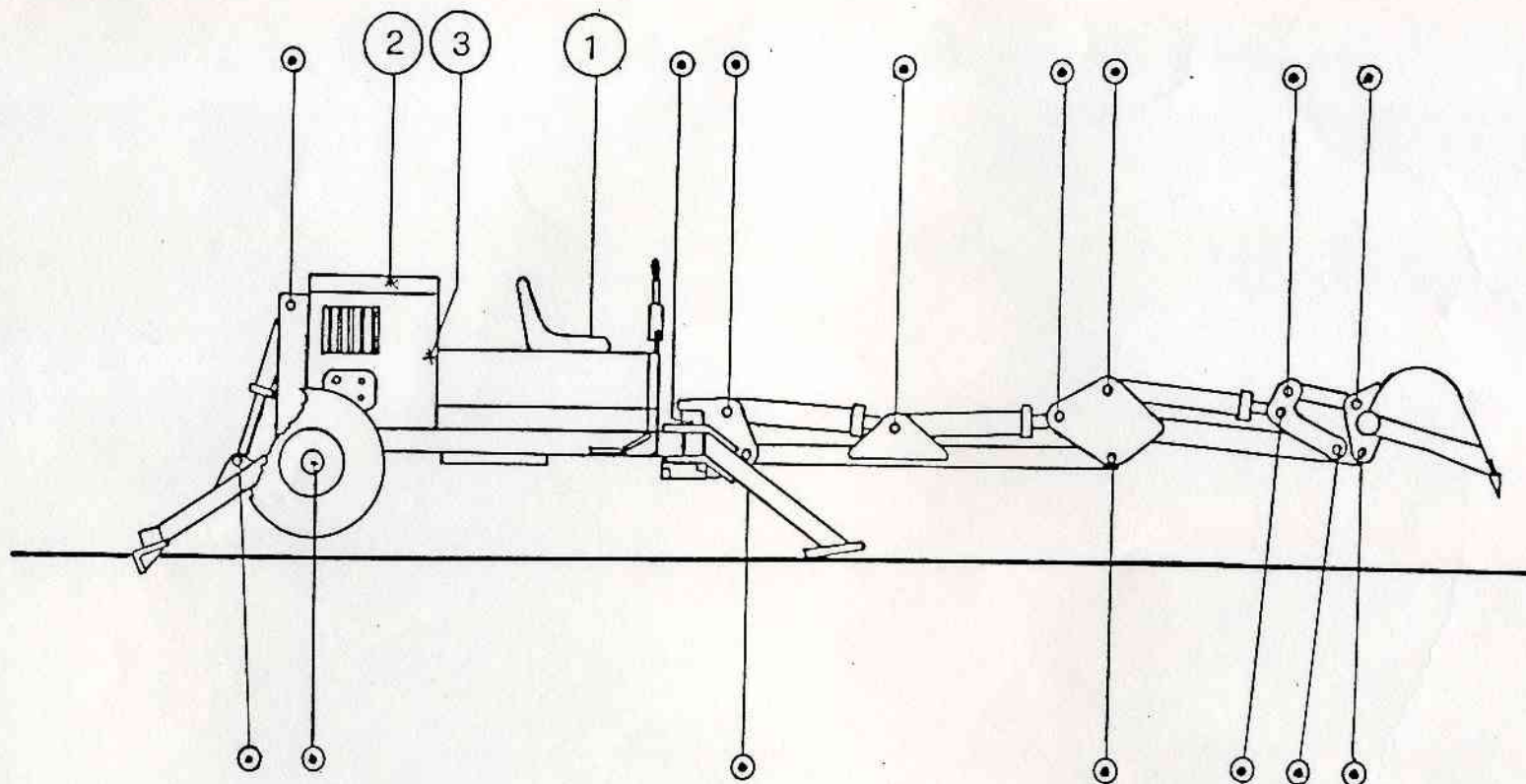

- \* See instruction manual of the engine manufacturers.
1. Hydraulic oil filter
  2. Diesel filter \*
  3. Engine oil filter \*
- ⊙ Greasing points.



PLANT & HYDRAULICS (U.K.) LTD  
 251 Hudders Road, Batley, West Yorkshire WF17 6JL  
 Tel: STD 0924 455096 09241 454621  
 Telex: 566188 PHHYDRALC  
 Specialists in Hydraulic Breakers

JOLLY

EUROMACH

DAILY MAINTENANCE - THIS IS TO BE CARRIED OUT BEFORE STARTING WORK.

1. - To check that all flexible rubber hydraulic pipes are in good condition and that no cuts or cracks are to be found. If any damage is found the respective pipe is to be repaired immediately.
2. - To check all connections to be in good condition and that there are no leaks. In case of leaks replace gasket on the connection its self.
3. - To check all rigid pipes to ensure they are in good condition. There should not be any dents or bends. In case any defects are found they are to be replaced.
4. - Check the hydraulic oil level, it should be around 1cm above the black line which is found on the oil level indicator in front of the tank. The excavator should be on level ground and it should be positioned as shown in Fig. 2. Recommended type of hydraulic oil to use is 1' IP IDROL 46.
5. - Check the pressure in the pneumatics which must be max. ATM.5 min ATM.4.
6. - Check the level on the distilled battery water, if needed top up.
7. - Check the engine oil level, if needed fill up (to check for engine oil and all other examinations refer to the maintenance manual from the manufacturers).
8. - Grease all parts indicated in drawing 2 as marked with black dots, giving particular attention at the joints of the arm.

PERIODIC MAINTENANCE.

1. - Change the hydraulic oil filter after the first 100 working hours. Make periodic checks after every 100 working hours ensuring to clean the filter every time.
2. - Check the wear and tear of the steel bushes and that of the nylon ones every 350 hours. If they are worn they are to be replaced.
3. - It is advised to give the excavator a general check up and service, checking the pull on the nuts and bolts every 5 - 700 hours, in case of necessity tighten all loose nuts and bolts.
4. - Change the hydraulic oil every 18 months, in doing this clean thoroughly the hydraulic tank ensuring all dirt is removed.
5. - Periodically check the pressure calibration in the hydraulic circuit. For this operation it is indispensable to refer to your authorised Euromach dealer as he is the only person authorised to remove the respective seals.

We reserve the right to change specifications without notification.



5640

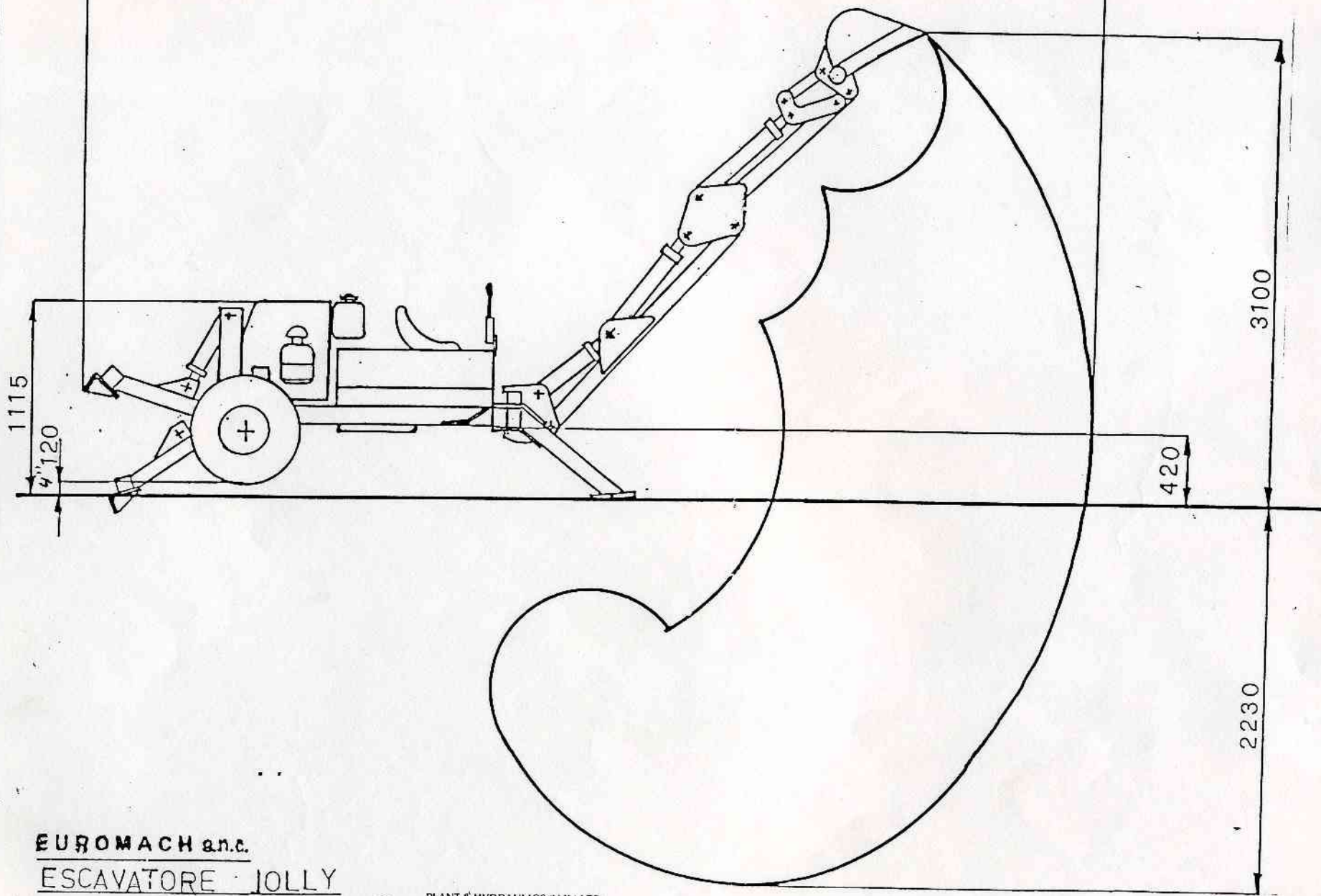

PLANT & HYDRAULICS (UK) LTD.  
231 BRADFORD ROAD  
BATLEY  
LEEDS WF17 6JL  
TEL. 0924-455090  
0924-454621

EUROMACH s.n.c.  
ESCAVATORE JOLLY



PLANT & HYDRAULICS (U.K.) LTD  
231 Bradford Road, Batley, West Yorkshire WF17 6JL  
Tel: STD 0924 455090 (0924 454621)  
Telex: 576155 UYFYBRA G  
Specialists in Hydraulic Breakers

**EUROMACH s.n.c.**  
**ESCAVATORE : JOLLY**



**PLANT & HYDRAULICS (U.K.) LTD**  
242 Bradford Road, Batley, West Yorkshire WF17 6JL  
Tel: 0113 491241 Fax: 0113 491242  
Telex: 550134P HYDRUK G  
*Specialists in Hydraulic Breakers*

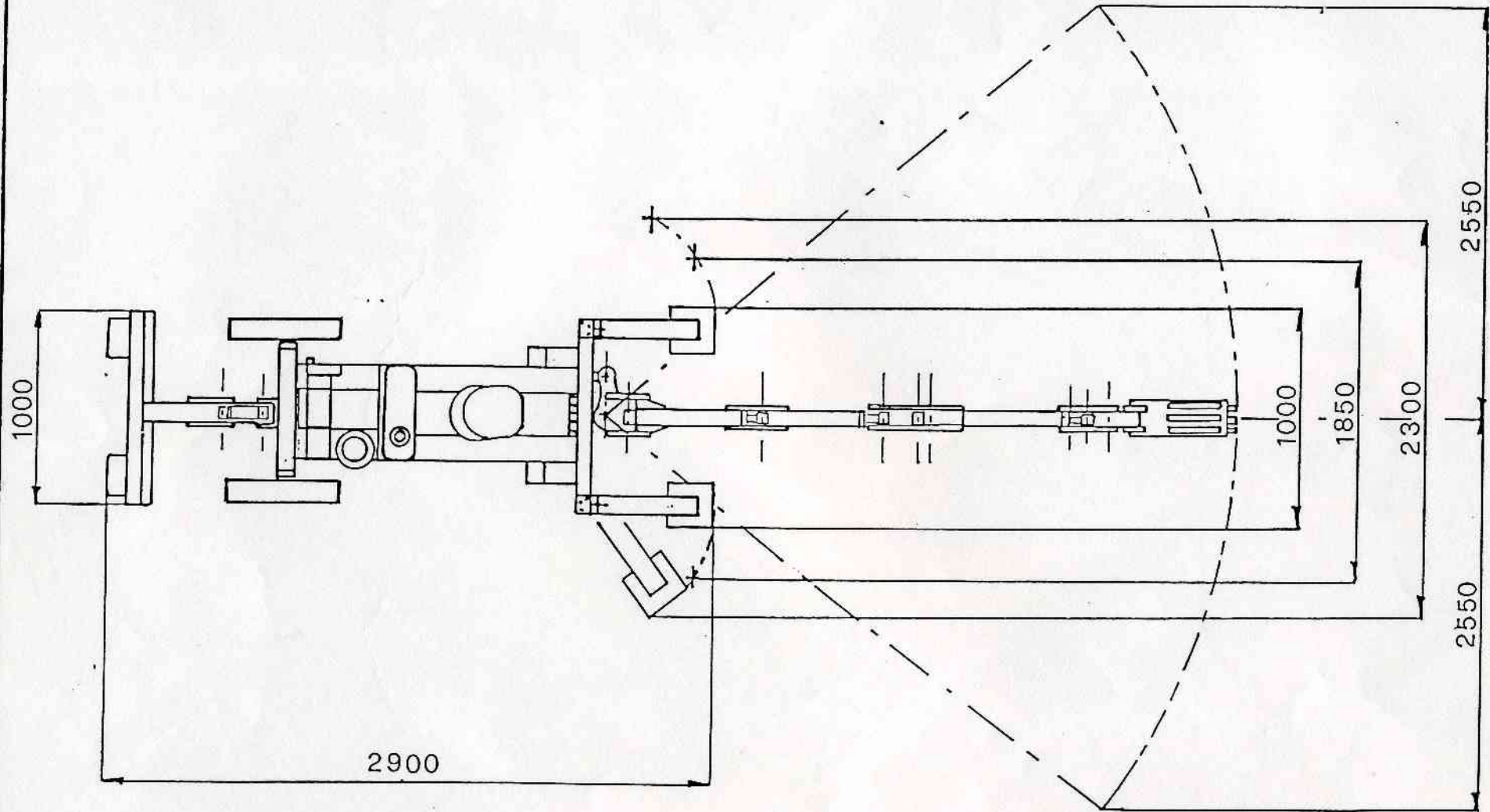

**PLANT & HYDRAULICS (UK) LTD.**  
**231 BRADFORD ROAD**  
**BATLEY**  
**LEEDS WF17 6JL**



HYDRAULIC INSTALATION.

1. - Geared hydraulic pump auto compensated tapped distributor valve comprising of 5 levers with anti shock valve and pressure limitator. LT/1<sup>0</sup> 32
2. - General calibration pressure. BAR 220
3. - Cylinders with double effect with measured stems and shafts. Retified recovered with hardend crome.
4. - Restocking of oil for operations up to 60<sup>0</sup>. Type required (36-CST-SAE 30)
5. - Capacity of hydraulic oil tank. LT 36
6. - Total hydraulic oil capacity LT 42
7. - Tank filter, filtration grade, 90
8. - Metalic meshed cartridge.
9. - Maximum filtrability (oil 5<sup>0</sup>E 50<sup>0</sup>C) LT/1<sup>0</sup> 100

STRUCTURE.

10. - All structures in steel with welded profiles.
11. - Articulations are with bushes in teperd steel.

EQUIPMENT AND ACCESSORIES.

12. - Control panel with ignision key, indicators for engine oil.
13. - Command controls grouped in 5 levers.
14. - Reversable bucket for digging 40cm.
15. - Series of keys for maintenance and greasing.

OPTIONAL ACCESSORIES.

Refer to distributor.

TECHNICAL CHARACTERISTICS.

16. - Working weight	800 KG
17. - Ground pressure	0.27 KG/CM
18. - Plant output	H.P. 12
<u>ENGINE.</u>	
19. - Cycle diesel 4 time cooled by air induction Bosch direct injection system, lubrification with pump	
20. - Gears, filter air oil immersed.	
21. - Cylinders	N. 1
22. - Bore	100 mm
23. - Stroke	94 mm
24. - Total cylinder capacity	738 cm
25. - Compression ratio	17, 5/1
26. - Max. output	KW/HP 12/16.3
27. - Calibration output	12 H.P.